

XENON RC-800

Modular UV Curing System

Now every application can benefit from a CoolCureXL solution.



You just found the solution to your curing challenge

The XENON RC-800 offers one of the safest, most flexible, highest-performing curing solutions available anywhere. These systems are proven worldwide in curing applications as diverse as optical discs, medical devices, pharmaceutical packaging, plastic bonding, wood coating, and many more.

If your application can benefit from energy efficient, rapid, cool curing at lower operating cost, we invite you to take a closer look at the new XENON RC-800. Then ask XENON's engineers to help you pick the ideal solution for your application.

Unique CoolCureXL technology

The RC-800 features XENON's unique CoolCureXL Pulsed Light technology, which delivers rapid curing without excessive heat. It's a significant improvement over mercury UV systems for the most demanding applications.

Wide range of options for process flexibility

Because the underlying technology is more versatile, the RC-800 Series offers more choices than mercury UV systems. You can choose from a wide range of high intensity pulsed UV lamps, housings and other options that let you mix-and-match a curing system to perfectly fit your application. You can use RC-800 systems for continuous inline and index curing applications.

Continuous or index operation

Based on XENON's decades of experience designing high-performing curing solutions, all RC-800 systems are designed for demanding inline processes that operate continuously, and for high-throughput indexing applications.

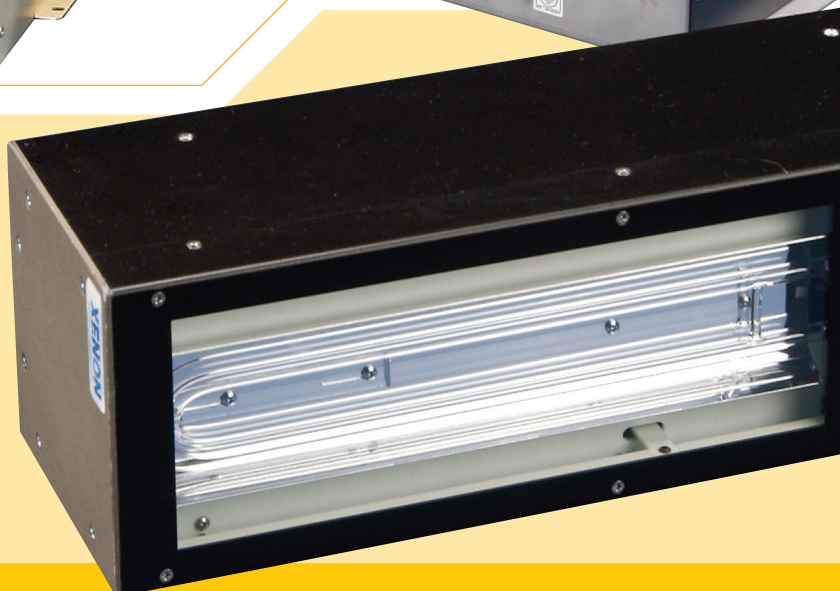

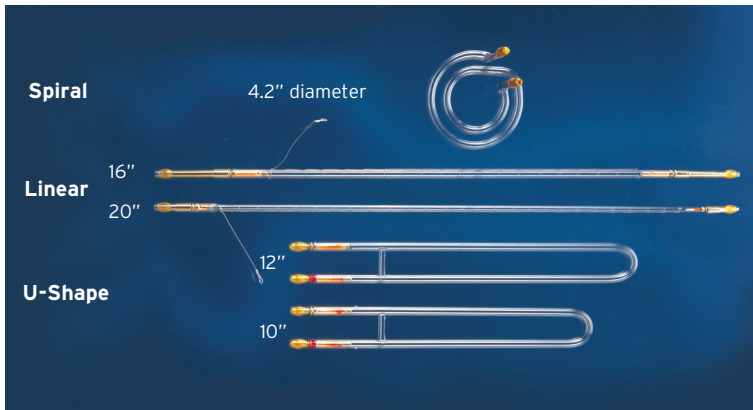

Unlike mercury UV lamps, which are limited to short arc or linear shapes, XENON's pulsed UV lamps can be virtually any size and shape to match your application's footprint.

A lamp design for your application

One of the keys to effective curing is matching the UV light "footprint" to the target size and shape. That's why XENON offers more choices in lamp shapes and sizes. Over the years, XENON has developed a wide array of lamp styles – so you can precisely match the optical footprint of the lamp to your needs. And we're constantly adding to our lamp selection to meet evolving customer requirements.

In addition, all RC-800 lamps offer a range of pulse rates and energies (up to 100 pulses per second; up to 507 joules per pulse), so they can be matched to a wide range of throughput requirements. Almost unlimited pulse sequencing can be user programmed, allowing an optimum match of UV light delivery to the target.

See the Selection Guide table on page 7 for the options and features that are available for different applications.



The RC-800 shown with LH-830 lamp housing

RC-800 single-lamp and dual-lamp systems

If you need one curing lamp to match your target area of exposure, choose the single-lamp system. For larger cure areas, consider choosing the dual-lamp system. Either system is available with any of XENON's lamp styles and shapes.

Multiple lamps made easy

Why a dual-lamp system? Multiple lamps allow a top-down, bottom-up and other curing strategies for higher throughput with low substrate temperatures. The dual-lamp configuration uses one power supply and one controller to operate both lamps. The two lamps are individually sequenced by the single controller's high-speed logic. You save money and reduce overall hardware requirements.



The RC-800 with dual LH-830 lamp housings

The science behind the solution

A unique merging of optics and electronics

The advanced features and benefits of the XENON RC-800 result from the merging of two sciences: optics and electronics. XENON has decades of experience in both fields and has applied them to practical curing challenges in many industries.

RC-800 systems are more than just lamps. They are carefully designed systems that optimize optics and electronics to deliver precisely controlled light pulses to meet specific curing objectives. Our scientists and engineers have unmatched experience in designing and implementing the most innovative, effective curing systems in the industry.

Understanding Pulsed Light: Why CoolCureXL technology is so cool

XENON's pulsed UV light technology has many inherent advantages over conventional mercury lamp technology, including lower power consumption, lamp flexibility, no warm up or cool down periods, wide spectrum and application-specific power levels to match both index and continuous curing operations.

But the attribute of Pulsed Light that truly sets it apart is the rapid and complete curing of UV materials, such as adhesives, inks, coatings, and paints, without generating excessive heat. The reason is the high peak energy of our Pulsed Light technology – peak energies can exceed 1 megawatt. UV curable formulations contain compounds called photoinitiators. Polymerization occurs when the photoinitiators receive UV radiant energy and create free radicals. If the radiant energy is not sufficiently intense, photoinitiators may not receive enough energy to create free radicals. The high peak energy of XENON's Pulsed Light technology results in deep penetration and complete curing. At the same time, the low average power of pulsed UV light does not generate the excessive heat that is typical of other UV curing systems.

Rapid curing without the heat. One more reason XENON's CoolCureXL systems are superior.

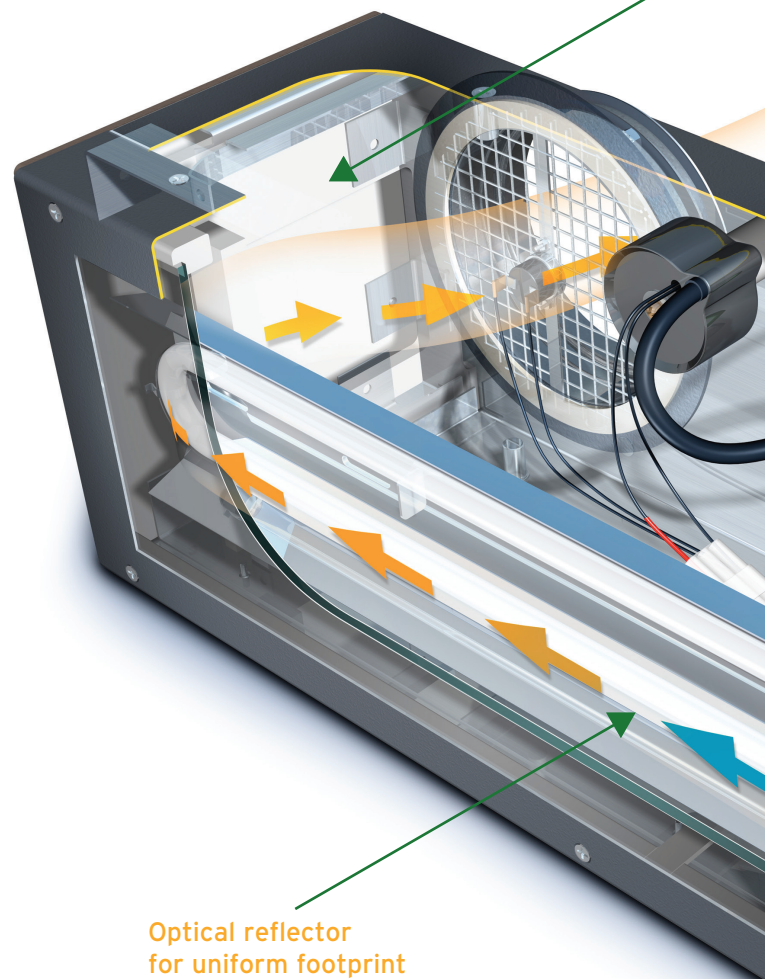



InterWeave Technology for continuous processes

XENON's InterWeave System (patent pending), optional for any dual-lamp RC-800 system, consists of a special 3 kW power supply and a controller that allows both lamps to be pulsed at the same rate, maximizing the conversion of energy into UV light. This means a dual-lamp system can effectively deliver up to 100 pulses/sec/lamp at 13 joules/pulse to provide cool curing in continuous processes.

Controlled airflow
for cool operation

Pulsed lamp for
maximum peak energy

Heat sink sockets
for long lamp life

The RC-800 offers:

- Deeper penetration for complete and consistent cures
- Less power consumption for lower cost of ownership
- Greater process flexibility
- Reduced cure time for much higher throughput
- Modular products for easy integration
- Mercury-free, environmentally sound technology

All the options you need for process flexibility

Along with a full range of lamp choices to match your curing needs, the C-800 offers multiple options to meet your process requirements.

You can choose from a range of lamps, lamp pulse energies, lamp pulse rates, light blocking filters, power supplies, lamp housing blower kits, and cable lengths. XENON engineers will help you integrate a system to match your manufacturing operations.

Installation is simple because, unlike mercury UV systems, there are no requirements for external water cooling equipment, mechanical shutters, or motors to rotate the substrate during the curing cycle. Only air cooling to the lamp housing is required.

Choice of lamp for UV/Visible curing

At XENON, we offer application-specific lamp types. The xenon lamp inherently produces a broadband spectrum suitable for any chemistry that absorbs UV light from 180 nm to 800 nm. Our lamps are available with up to four different spectral cut-offs, producing wavelength properties suitable for specific types of curing challenges. You can also choose from a variety of lamp shapes, including our patented spiral lamp. A XENON application engineer will help you choose the best lamp for your needs.

Effective spectral cut-off point:

- Lamp A: 370 nm: best for visible light cures. No ozone.
- Lamp B: 240 nm: optimum UV performance. No ozone.
- Lamp C: 190 nm: cuts off deeper UV. Ozone.
- Lamp D: 160 nm: allows deep UV. Ozone.

Shown below is a typical spectrum for a C lamp:

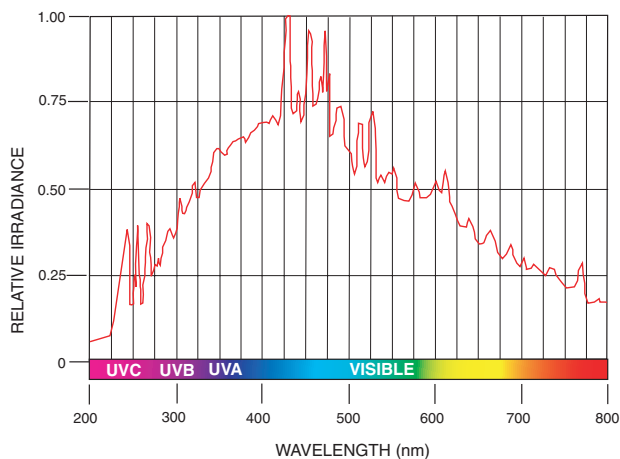

Choice of pulse rates

A key to successful curing is the pulse rate of the UV light. RC-800 systems can be factory set with pulse rates ranging from 3 pps to 100 pps.







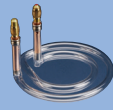

Choice of burst mode

The instant ON/OFF capability of the C-800 systems allows them to operate in burst mode if desired. The burst mode can be set by the user to match certain applications, such as start-stop-start manufacturing processes. You can program the lamp duty cycle from a single pulse to 100%. Burst mode also saves energy since the lamp duty cycle is typically only 50%, and often as low as 5%.

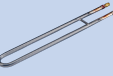
Additional options to match your specific needs:

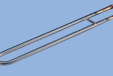
- **LiteMark-XL™ Pulsed UV detection system.** This module allows real-time performance monitoring of radiant energy from a XENON flash lamp system, providing instantaneous data for process monitoring and control.
- **Data logger.** This option lets you connect the LiteMark-XL to a computer to display and record light intensity data. The system operator can observe the data on a computer monitor in tabulated and graphical form.
- **Timer control module.** A manually controlled timer module is available, in applications where the RC-800 is not under computer control. This module turns the lamp ON and OFF by simple switch commands, and includes a timed mode that can be selected by the operator. The module can be used with a single-lamp, dual-lamp, with or without the InterWeave system.
- **Switch control module.** This module can be chosen when you want the operator to have manual control of a RC-800 system. It can be used with all RC-800 configurations – single-lamp, dual-lamp, with or without the InterWeave.
- **Power supplies for different energy levels.** RC-800 systems offer a wide range of energy levels, from 13 joules/pulse up to 507 joules/pulse. A choice of power supplies matched to the selected output gives your system the optimum performance and cost-effectiveness.

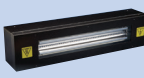
Selection Guide Table

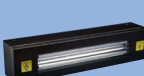
CURING CHALLENGE		SOLUTION				
Application	Curing Area	Lamp	Pulse Energy	Model	Lamp Shape	Housing
Optical Disc Lens Coating Tape Release Hard Disc Credit Card	Circular 5.5" diameter	B, C, D	13 joules/pulse 15 joules/pulse 207 joules/pulse	LH-810		
Wood Coating Plastic Bonding Surface Preparation Printing	Rectangular 10" x 3"	B, C	13 joules/pulse 15 joules/pulse	LH-820		
Wood Coating Plastic Bonding	Rectangular 12" x 3"	B, C	13 joules/pulse 15 joules/pulse	LH-830		
Ink Jet Printing	Rectangular 16" x 1"	B, C, D	507 joules/pulse	LH-840		
Lubricious Coating Hydrogels Powder Coatings Surface Preparation Wood Coating	Rectangular 20" x 1" or 20" x 2"*	A, B, C	13 joules/pulse 15 joules/pulse	LH-850		

*Curing area for LH-850 with elliptical reflector is 20" x 1", with radial reflector it is 20" x 2".

XENON Corporation is the world leader in Pulsed Light technology for a wide variety of industrial, medical and research applications. XENON Corporation designs and manufactures high performance pulsed UV lamps, curing systems, and sanitization systems. XENON offers:

- A proven history of meeting the worldwide need for High Performance Pulsed Light in Science, Industry, Medical, and Electronics since 1964
- An unmatched depth of experience to provide solutions in the most challenging applications
- One-stop shopping capability from components to complete systems

XENON enjoys a reputation for superior customer service and sophisticated products that are rugged and reliable. Hundreds of end-users and OEMs worldwide depend upon XENON products for longer life, greater reliability, and less down time.

Our engineers will help you configure your ideal curing solution. We invite you to visit our labs and bring your application with you or contact us to arrange a conference call with our engineers. At XENON, we step our customers through the discovery process of pulsed UV light curing. And we're ready to work with you to make your application a success.

Call us with your demanding application, and see what our engineers can do.



The Pulsed Light Experts

XENON Corporation
37 Upton Drive
Wilmington, MA 01887-1018 USA

Telephone 978-661-9033
Toll Free 800-936-6695 (U.S.A. only)
Fax 978-661-9055
Email info@xenoncorp.com
Web www.xenoncorp.com

Talk to XENON today

XENON Corporation is a pioneer in Pulsed Light technology. Our unique, patented lamps are used in a wide range of industries and applications. XENON's applications engineers are available to help you customize a curing solution for you. To learn more, visit www.xenoncorp.com.

© 2014 XENON Corporation. All rights reserved. No part of the contents of this brochure may be reproduced without the written permission of XENON Corporation. XENON, the XENON logo and InterWeave are trademarks of XENON Corporation. All other trademarks are the property of their respective owners.